

THIS DRAWING IS UNPUBLISHED.

RELEASED FOR PUBLICATION

LOC EK DIST 00

REVISIONS

© COPYRIGHT 2005 BY TYCO ELECTRONICS CORPORATION. ALL RIGHTS RESERVED.

| P | LTR | DESCRIPTION | DATE | DWN | APVD |
|---|-----|-----------------------------|---------|-----|------|
| | L | REVISED PER EC 0S14-0457-04 | 03NOV05 | TS | JL |

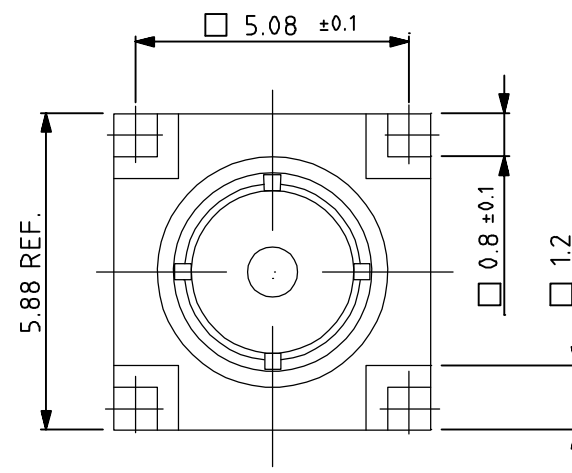
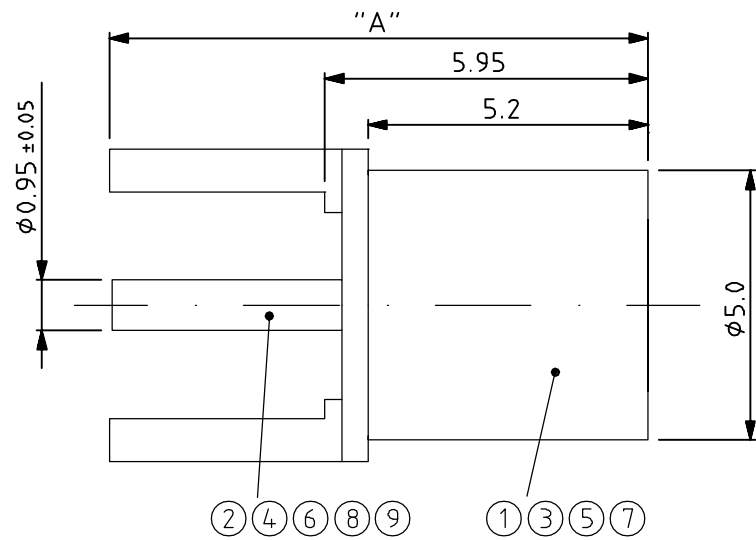

LEITERPLATTENBOHRBILD
PC-BOARD LAYOUT

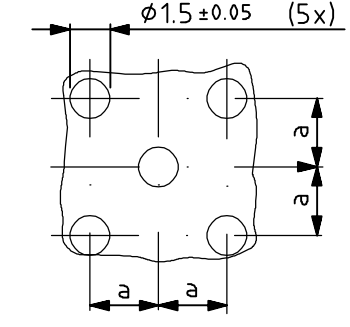

a = 2.54 ± 0.05

- 1 KOAX STECKVERBINDER NACH CECC 22220
COAX CONNECTOR COMPLIES WITH SPEC. CECC 22220
- 2 1 KOAX - KUPPLER IM PLASTIKBEUTEL VERPACKT
1 COAX JACK PACKED IN PLASTIC BAG

- 3 VERGOLDET 112-162-5; 1.3µm MIN DICKE ÜBER Ni 112-25-2; 2.0µm MIN - 4.0µm MAX DICKE
GOLD PL. 112-162-5; 1.3µm MIN THK OVER Ni PL. 112-25-2; 2.0µm MIN - 4.0µm MAX THK
- 4 VERGOLDET 112-162-5; 0.8µm MIN DICKE ÜBER Ni 112-25-2; 2.0µm MIN - 4.0µm MAX DICKE
GOLD PL. 112-162-5; 0.8µm MIN THK OVER Ni PL. 112-25-2; 2.0µm MIN - 4.0µm MAX THK

- 5 VERGOLDET 0.1-0.2µm DICKE ÜBER NOM. 4.0µm Ni P DICKE
0.1-0.2µm Au OVER NOM. 4.0µm Ni P PLATING
- 6 100 KOAX - KUPPLER IM PLASTIKBEUTEL VERPACKT 5 PLASTIKBEUTEL IN 1 KARTON
100 COAX JACK PACKED IN PLASTIC BAG 5 PLASTIC BAGS IN 1 CARTON BOX

| DIM "A" | 6 | | 2 | | POS. ITEM-NO. | STÜCK PIECES | BENENNUNG EINZELTEIL DESCRIPTION | WERKSTOFF MATERIAL | OBERFLÄCHE PLATING FARBE/COLOUR |
|---------|----------------------|----------------------|---|---|-----------------------------|--------------|----------------------------------|--------------------|---------------------------------|
| | BESTELL-NR. PART-NO. | BESTELL-NR. PART-NO. | 9 | 1 | | | | | |
| 8.5 | 5-82958-5 | 82958-5 | 9 | 1 | BUCHSENKONT./FEMALE CONTACT | | Cu Be / BZ4 | 4 | |
| | | | 3 | 1 | KUPPLER/JACK | | Cu Zn | 5 | |
| 8.5 | 5-82958-4 | 82958-4 | 8 | 1 | BUCHSENKONT./FEMALE CONTACT | | Cu Be / BZ4 | 3 | |
| | | | 7 | 1 | KUPPLER/JACK | | Cu Zn | 4 | |
| 8.5 | 5-82958-3 | 82958-3 | 6 | 1 | BUCHSENKONT./FEMALE CONTACT | | Cu Be / BZ4 | 5 | |
| | | | 5 | 1 | KUPPLER/JACK | | Cu Zn | 5 | |
| 10 | 5-82958-2 | 82958-2 | 4 | 1 | BUCHSENKONT./FEMALE CONTACT | | Cu Be / BZ4 | 5 | |
| | | | 3 | 1 | KUPPLER/JACK | | Cu Zn | 5 | |
| 10 | 5-82958-1 | 82958-1 | 2 | 1 | BUCHSENKONT./FEMALE CONTACT | | Cu Be / BZ4 | 3 | |
| | | | 1 | 1 | KUPPLER/JACK | | Cu Zn | 4 | |

THIS DRAWING IS A CONTROLLED DOCUMENT.

| | |
|-----------------------|--|
| DIMENSIONS: mm | TOLERANCES UNLESS OTHERWISE SPECIFIED: |
| | 0 PLC ± - |
| | 1 PLC ± - |
| | 2 PLC ± 0.15 |
| | 3 PLC ± - |
| | 4 PLC ± - |
| | ANGLES ± - |
| MATERIAL SEE TABLE | FINISH SEE TABLE |

| | | | |
|----------------------|-------------------------|---|--|
| DWN ZANDER 13FEB91 | tyco Electronics | Tyco Electronics Corporation Harrisburg, PA 17105-3608 | |
| CHK - | | NAME | |
| APVD FISCHER 13DEC90 | PRODUCT SPEC | | COAXICON SERIES MCX, -JACK FOR PCB (PITCH 5.08 mm) |
| APPLICATION SPEC | SIZE A3 | CAGE CODE 00779 | DRAWING NO. C-829558 |
| WEIGHT - | RESTRICTED TO - | | SCALE 1:1 |
| CUSTOMER DRAWING | SHEET 1 OF 1 | | REV L |